

# Ultrasonic Waveguides for Remote High Temperature NDT

**F. B. Cegla, P. Cawley**

Non-Destructive Testing Group

Department of Mechanical Engineering

Imperial College London

SW7 2AZ

United Kingdom

# Plan of the talk

- Motivation
- HT US Approaches
- Challenges using a waveguide
- Current high temperature thickness gauge
- High temperature Crack monitoring
- Summary
- Future Developments

## Ultrasonic plant inspection

- Inspection when cold at shut down
  - Intervals ~4-5 years
  - Aging plants
  - High cost of unexpected events
- Need for monitoring during operation  
even at high temperatures ( $>300^{\circ}\text{C}$ )



## Conventional ultrasonic probes at high temperature

- Depolarisation of piezo crystal
- High demands on (cables, housing, etc.)
- coupling is very difficult
- cooling is expensive



## Approach 1

(Develop HT piezo crystal)

- expensive materials
- reduced sensitivity
- coupling issues
- HT envir. for all components

## Approach 2 (Develop “Acoustic cable”)

- Separation of transduction from specimen environment
- Use of conventional strong piezo materials
- Flexible cable to reach into inaccessible areas
- Good dry coupling of cable to specimen



## Waveguide system development Challenges

- Wave propagation in the waveguide
- Source characteristics on the specimen

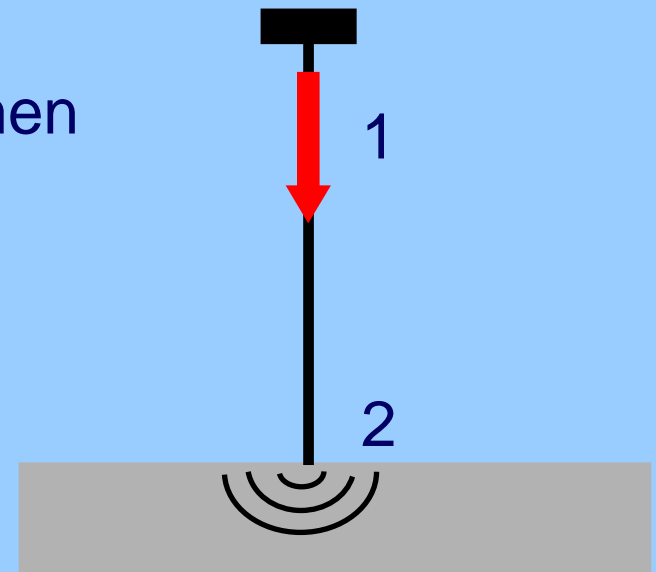

## Prototype

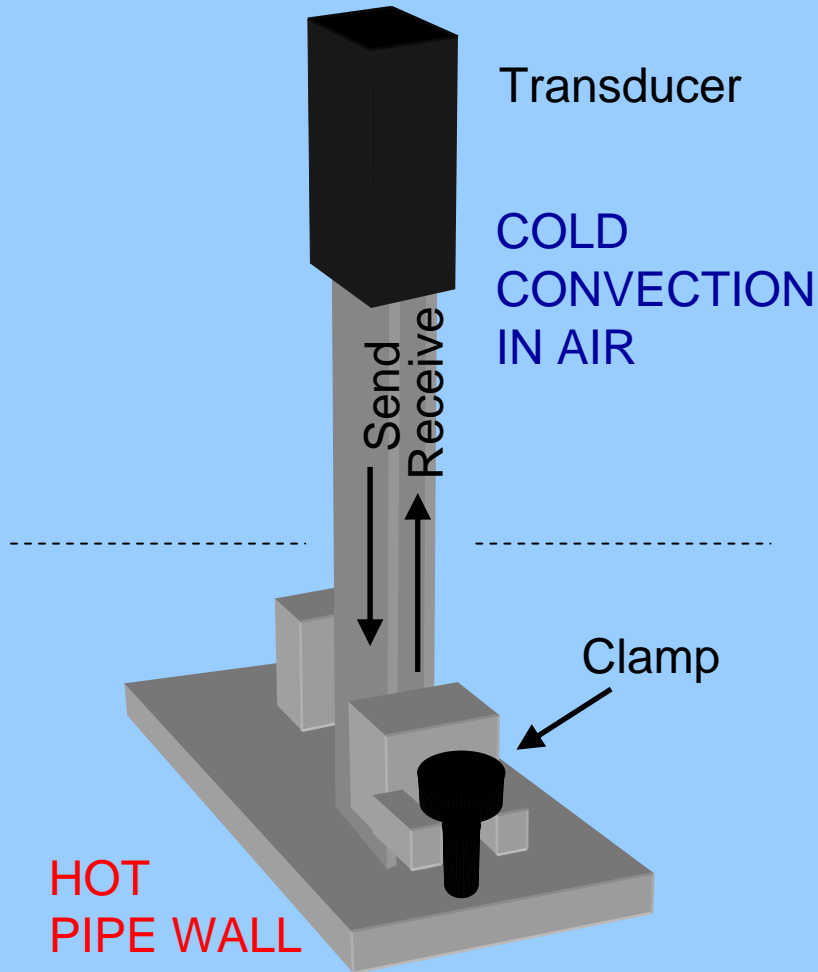

- 2 Strips (send/receive)
- dry coupling (clamp)
- 3 to 20 mm Thickness range
- Tested at 600 °C for months

## Results

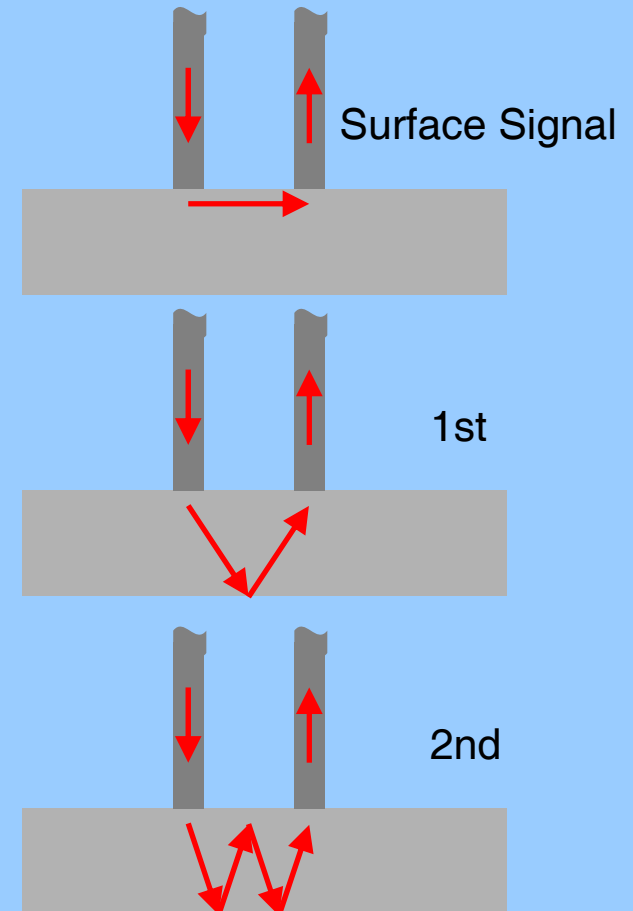
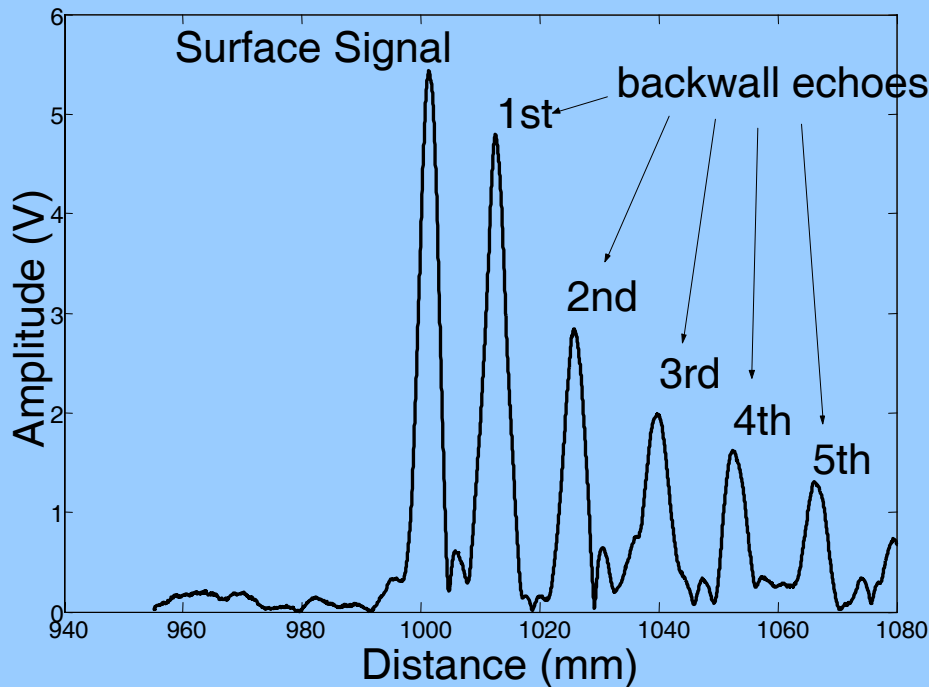

600°C, >2 months, Temp. cycling → no changes

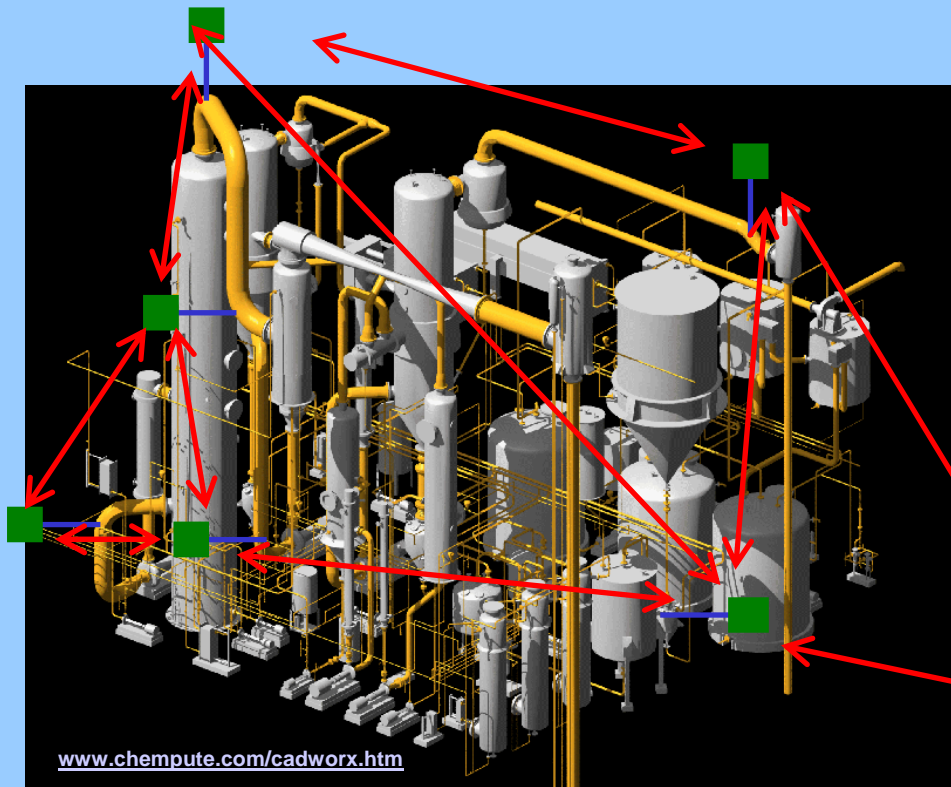

- Wireless network
- sensor at critical points
- Intrinsically safe sensors
- Data transfer to base station

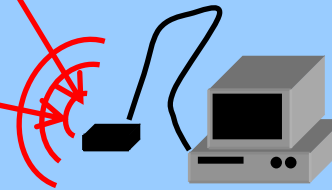

- Prevent prolonged shut downs
- Monitor known cracks
- Monitor under running conditions

(1) TOFD

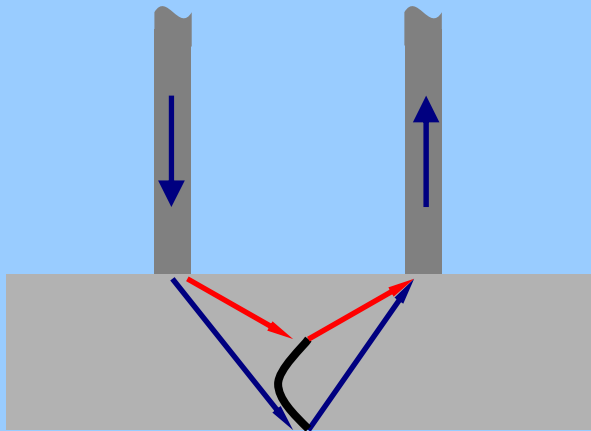

(2) Shielding

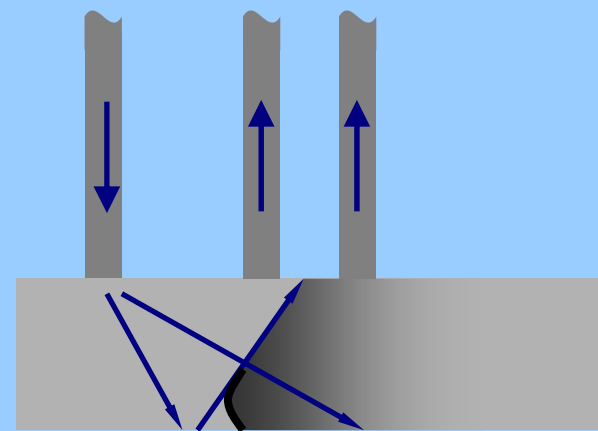

## TOFD (Time of Flight Diffraction)

- Use of Shear horizontal waves (instead of longitudinal)
- Geometry
- SH wave diffraction directivity

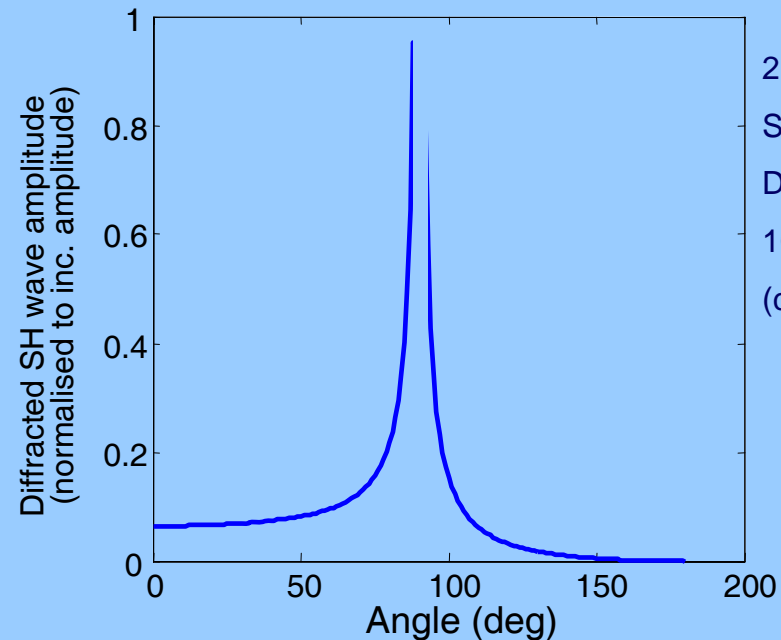
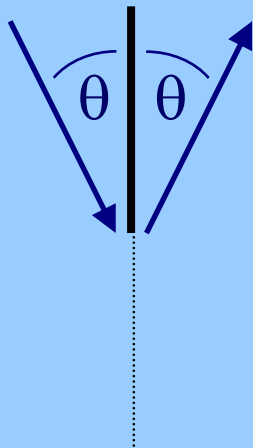

2MHz SH wave in  
Steel, amplitude of  
Diffracted wave at  
10mm from crack tip  
(calc. after Chapman)

# TOFD (Time of Flight Diffraction)

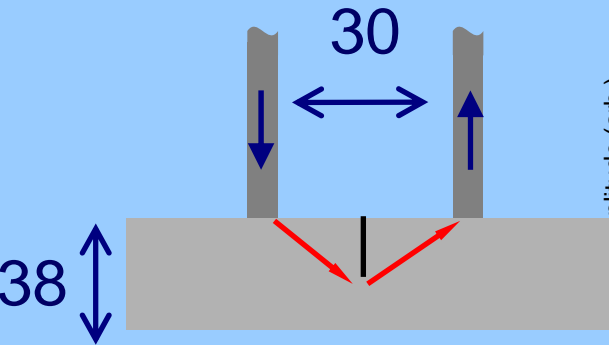

## Experiment (notch)

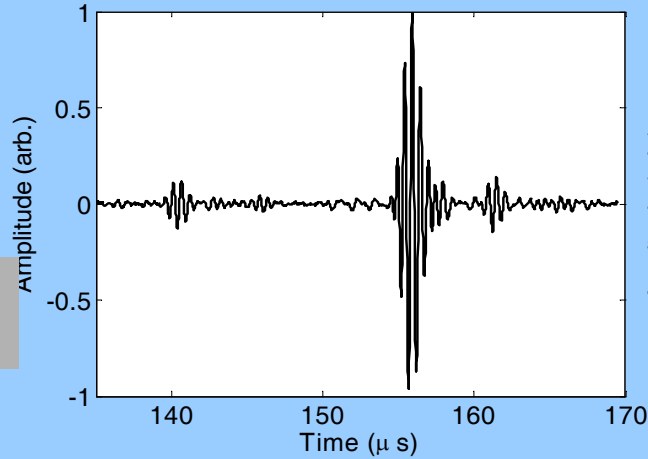

## Simulation (crack)

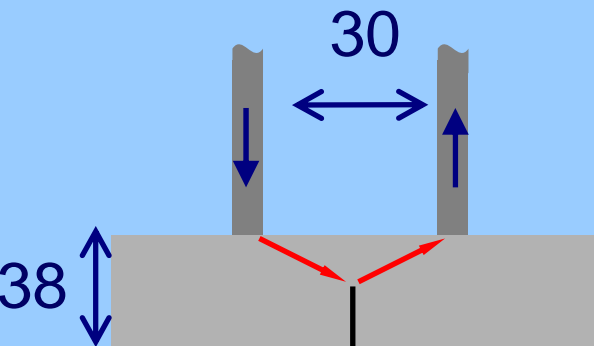
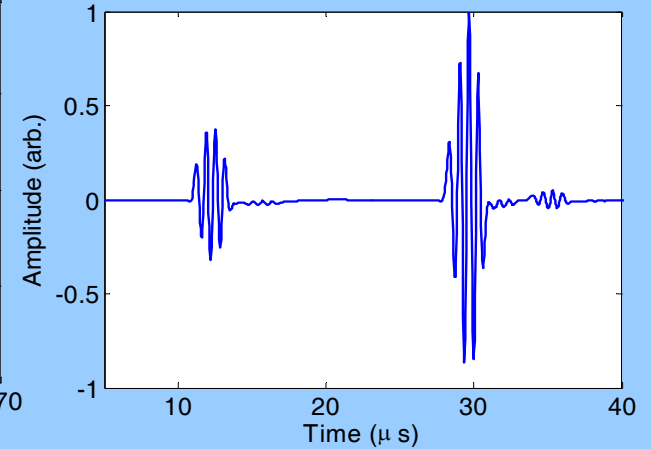

## Experiment (notch)

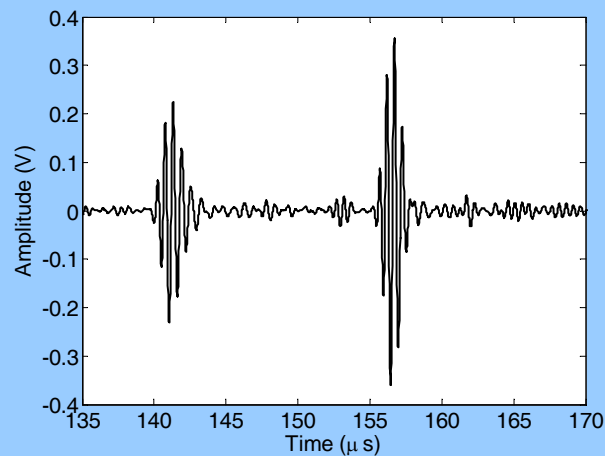

## Simulation (crack)

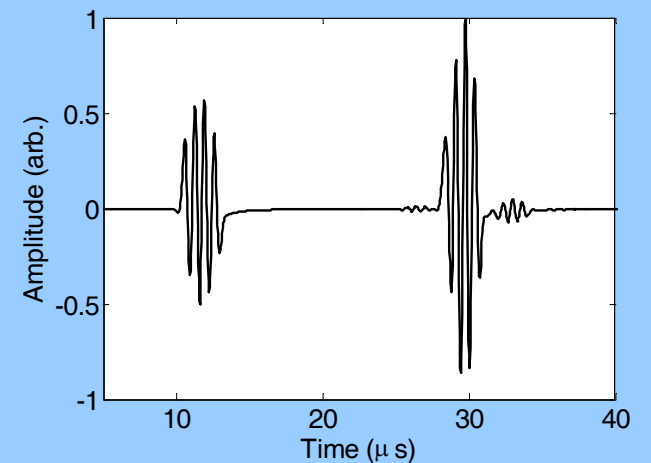

## Shielding

Incident wave at 90 deg



Monitoring plane

$y = 19\text{mm}$

Half plane screen

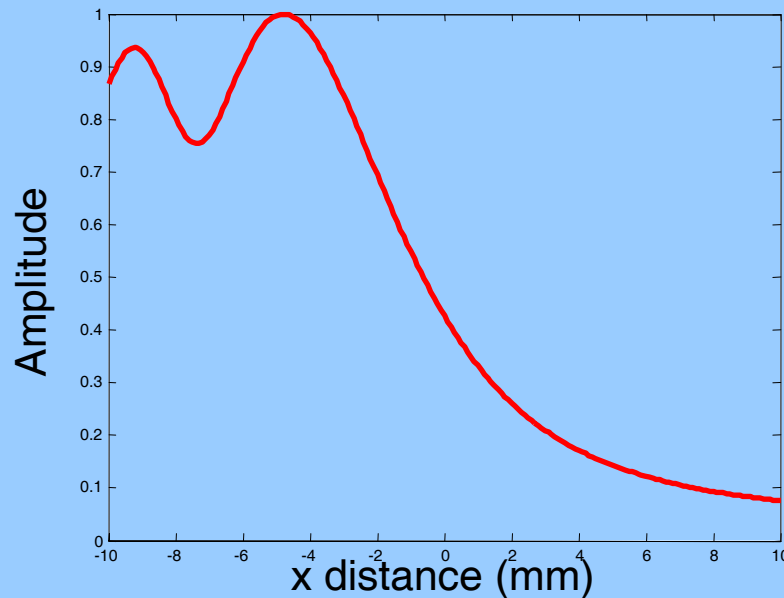

# Crack monitoring

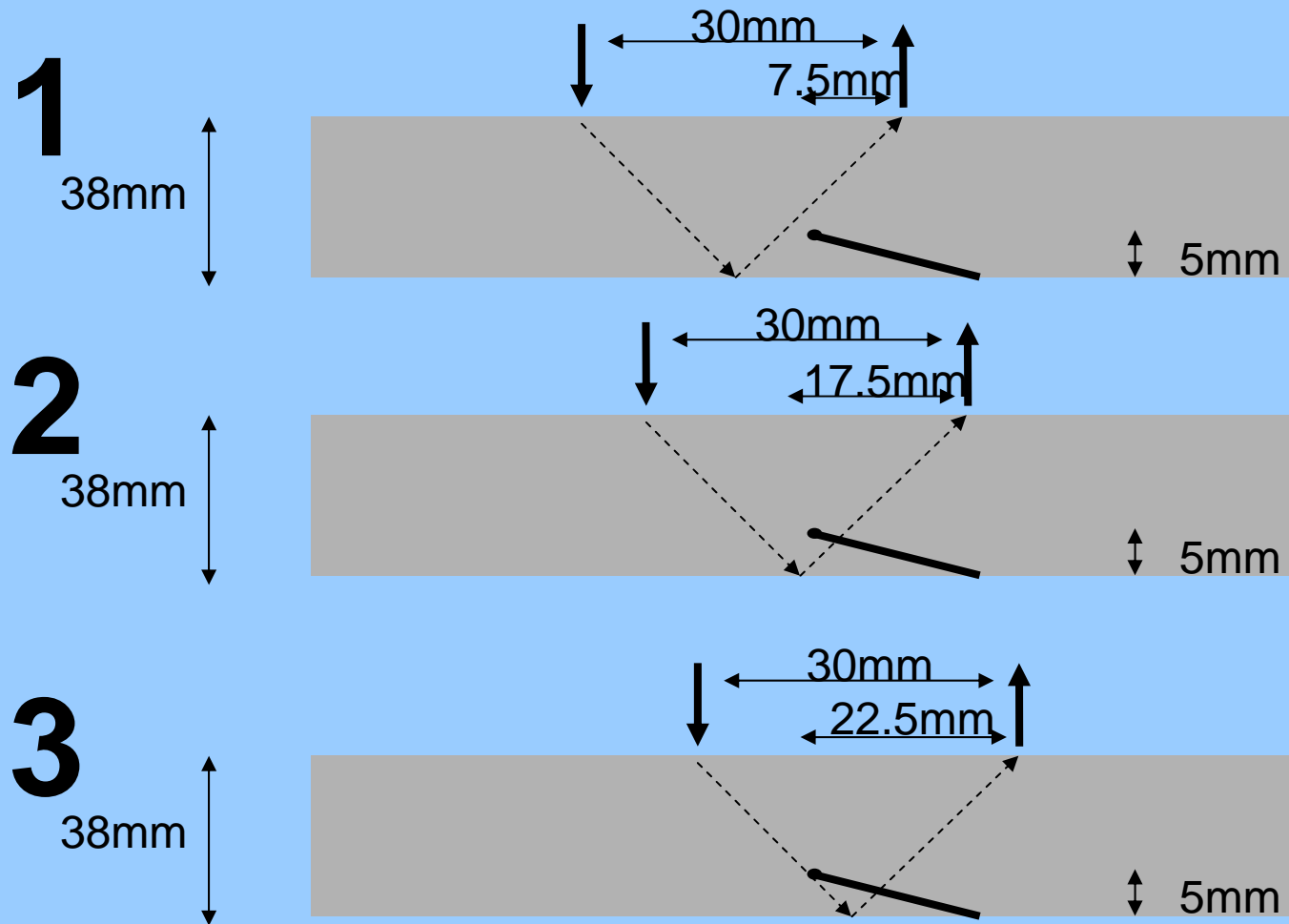

# Crack monitoring

1

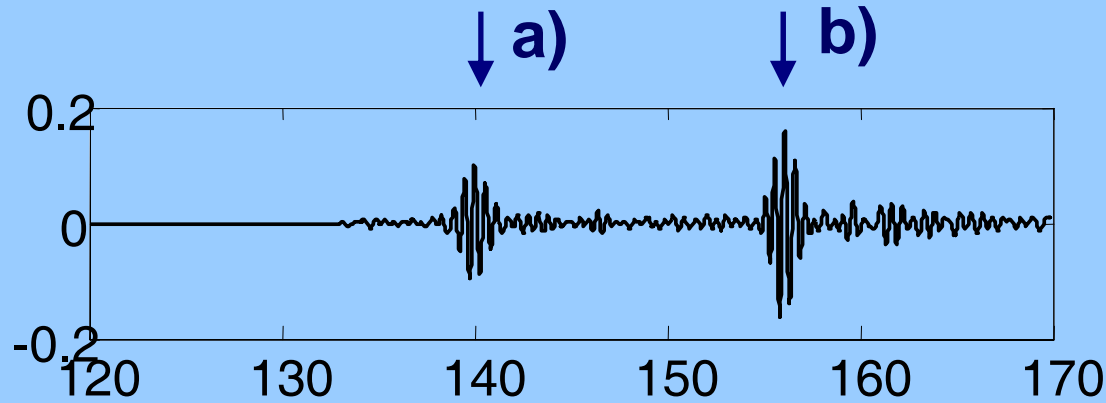

a) surface  
signal

2

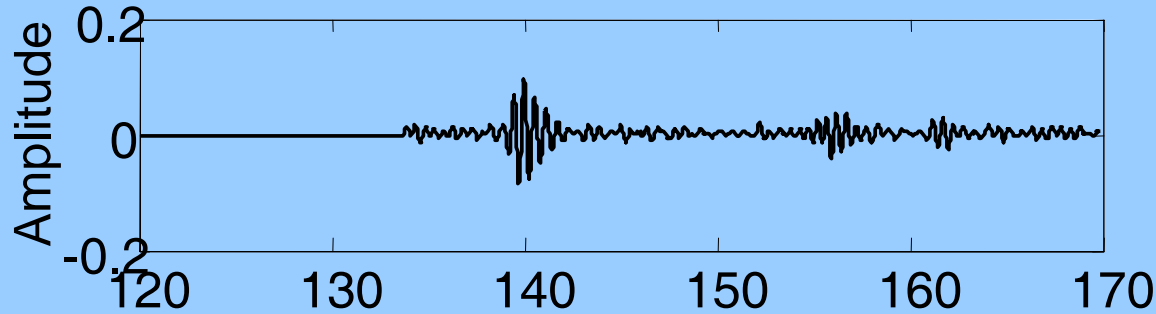

b) backwall  
signal

3

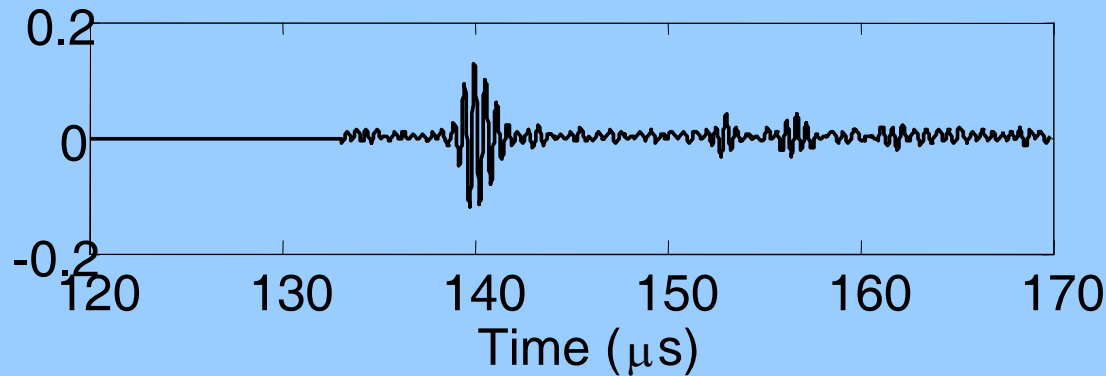

- Waveguide sensor for high temperature thickness gauging
  - SH wave excitation
  - Dry coupling using clamp
  - Tested at high temperatures
  - Development of a wireless system
- Crack monitoring strategies
  - TOFD
  - Shielding

- Experiments on real cracks
- Establish best operating regimes for each technique
- Investigate the use of arrays
- High temperature trials

# Wave propagation

∅5mm rod, 150mm long

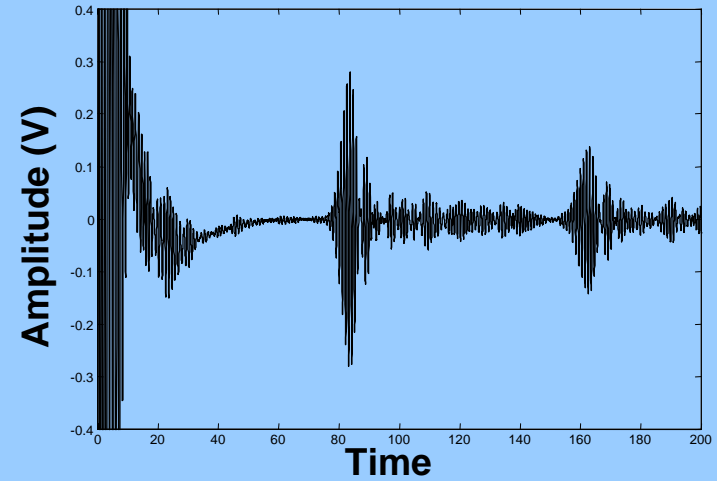
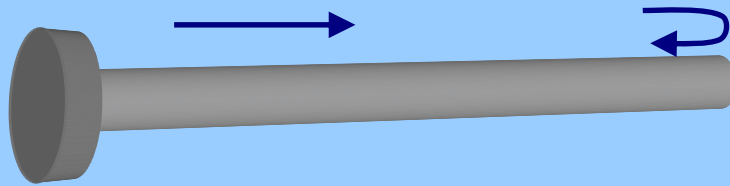

15x1x200mm optimised waveguide

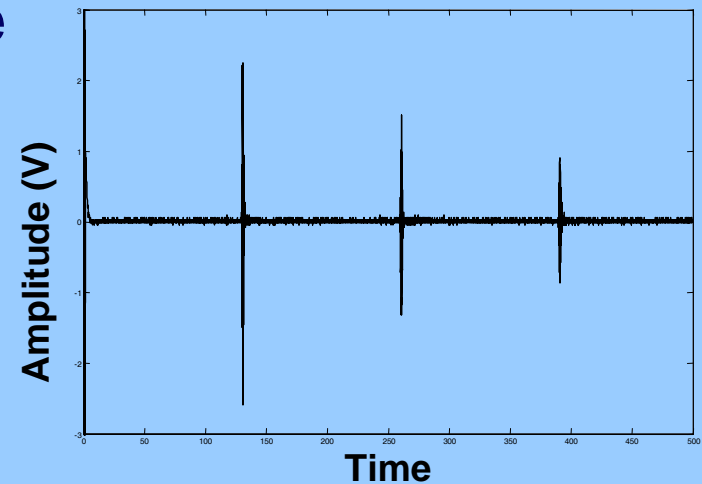
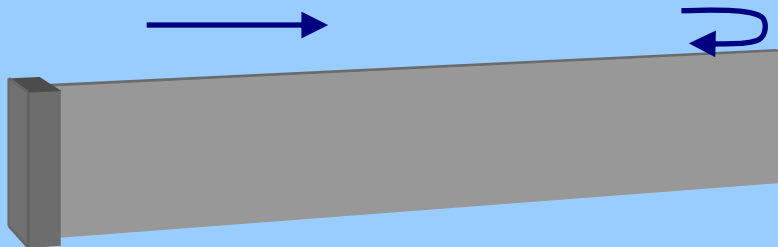

## Normal point source on a half space

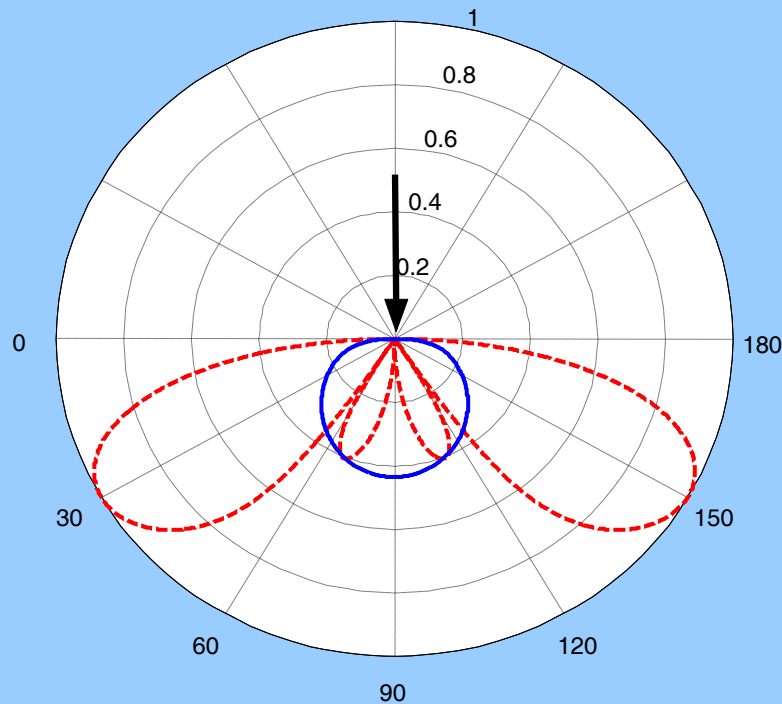

- Compression wave (7%)
- - - Shear wave (26%)
- Surface wave (67%)

# Source characteristic

